

	I	GB	D	F	E
ICW 1-2 Ø 2" G	INGRESSO ACQUA REFRIGERATA	CHILLER WATER INLET	KALTWASSEREINGANG	ENTREE EAU GLACEE	ENTRADA AGUA ENFRIADA
UCW 1-2 Ø 2" G	USCITA ACQUA REFRIGERATA	CHILLER WATER OUTLET	KALTWASSERAUSSGANG	SORTIE EAU GLACEE	SALIDA AGUA ENFRIADA
IHW Ø 1 1/4" G	INGRESSO ACQUA CALDA	HOT WATER INLET	WARMWASSEREINGANG	ENTREE EAU CHAUDE	ENTRADA AGUA CALIENTE
UHW Ø 1 1/4" G	USCITA ACQUA CALDA	HOT WATER OUTLET	WARMWASSERAUSSGANG	SORTIE EAU CHAUDE	SALIDA AGUA CALIENTE
IP a-b	INGRESSO CAVO DI ALIMENTAZIONE	POWER SUPPLY CABLE INLET	SPEISEKABELINGANG	ENTREE CABLAGE D'ALIMENTATION	ENTREE CABLAGE ALIMENTATION
IS	INGRESSO USCITA SEGNALI	SIGNALS INLET / OUTLET	EINGANG / AUSGANG SIGNALE	ENTREE / SORTIE SIGNALES	ENTRADA / SALIDA SINIALIZACIONES
IR	INGRESSO RETE	NETWORK INLET	NETWORKEINGANG	ENTREE RESEAU	ENTRADA RED
F Ø 6	INGRESSO ACQUA UMIDIFICATORE	HUMIDIFIER WATER INLET	WASSEREINGANG BEFEUCHTER	ENTREE EAU HUMIDIFICATEUR	ENTRADA AGUA HUMECTADOR
C-D Ø 32	SCARICO ACQUA UMIDIFICATORE E/O CONDENSA	HUMIDIFIER / CONDENSATE DRAIN CONNECTION	KONDENSAT - BZB. BEFEUCHTERABFLUSS	DECHARGE EAU HUMIDIFICATEUR ET/OU CONDENSEUR	DESCARGA AGUA HUMECTADOR Y/O CONDENSADOR
AR Ø 100	INGRESSO ARIA DI RINNOVO	FRESH AIR INLET	FRISHLUFTEINGANG	ENTREE AIR NEUF	ENTRADA AIRE DE RENOVO

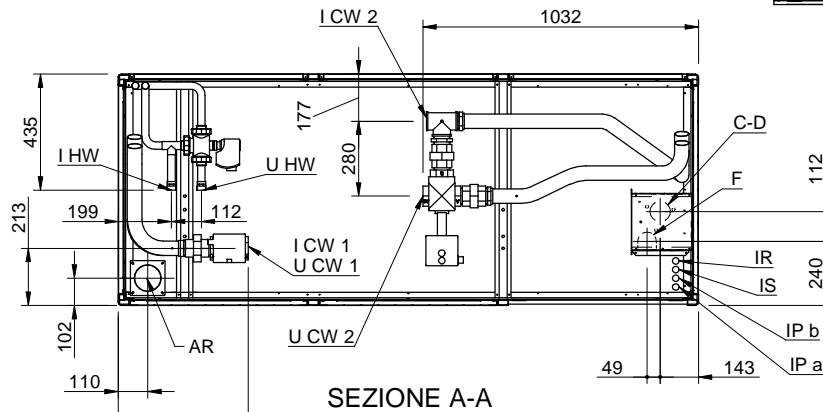

ICW2 - UCW2 = SOLO PER VERSIONE DUAL COIL  
ONLY VERSION DUAL COIL  
NUR VERSION DUAL COIL  
SEULEMENT VARIATION DUAL COIL  
SOLO VERSION DUAL COIL

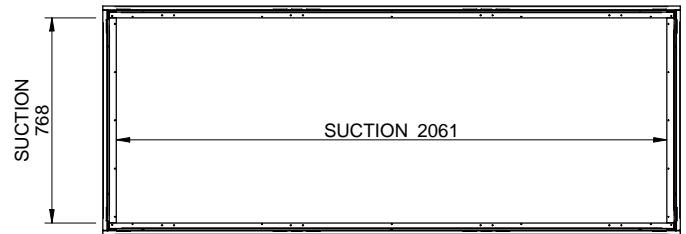
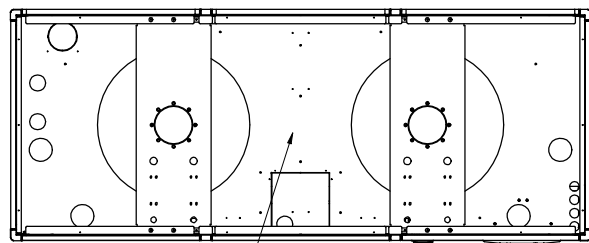

USCITA ARIA REFRIGERATA  
TREADED AIR DISCHARGE  
ZULUFTAUSGANG  
SORTIE AIR GLACEE  
SALIDA AIRE ENFRIDA

C	Aggiunto uscite Dual Coil	M.Chiodetto	09/05/08		
REV.	Descrizione - Description	Disegnatore - Draftsman	Data - Date	Visto - Checked by	n' Com.
Materiale - Material	Trattamento - Treatment		Rif. Com.		
		Denominazione-Denomination <b>DISEGNO DI INSTALLAZIONE</b> <b>INSTALLATION DRAWING</b>		Series <b>TUC</b> Modello-Model <b>2000...2700</b>	
Scala-Scale	QUOTE SENZA INDICAZIONE DI TOLLERANZA <b>Grado di precisione medio</b> <b>UNI EN 22768-1(1996)</b>	Dis.-Draftsman <b>A.Miotto</b> Visto-Checked by	Foglio - Sheet N. <b>1/1</b> Data-Date <b>05/10/2005</b>	Disegno-Drawing <b>DICI901X2A</b>	REV. <b>C</b>